

Data acquisition system of the CANGAROO-III telescope

H. Kubo¹, A. Asahara¹, G.V. Bicknell², R. W. Clay³, P. G. Edwards⁴, R. Enomoto⁵, S. Gunji⁶, S. Hara⁷, T. Hara⁸, S. Hayashi⁹, C. Itoh¹⁰, S. Kabuki⁵, F. Kajino⁹, H. Katagiri⁵, A. Kawachi⁵, T. Kifune¹¹, J. Kushida⁷, S. Maeda⁹, A. Maeshiro⁹, Y. Matsubara¹², Y. Mizumoto¹³, M. Mori⁵, H. Muraishi¹⁴, Y. Muraki¹², T. Naito⁸, T. Nakase¹⁵, K. Nishijima¹⁵, M. Ohishi⁵, K. Okumura⁵, J. R. Patterson³, R. J. Protheroe³, K. Sakurazawa⁷, R. Suzuki⁵, D. L. Swaby³, T. Tanimori¹, F. Tokanai⁶, K. Tsuchiya⁵, H. Tsunoo⁵, K. Uruma¹⁵, A. Watanabe⁶, S. Yanagita¹⁰, T. Yoshida¹⁰, and T. Yoshikoshi¹⁶

¹Department of Physics, Faculty of Science, Kyoto University, Sakyo-ku, Kyoto, Kyoto 606-8502, Japan

²MSSSO, Australian National University, ACT 2611, Australia

³Department of Physics and Math. Physics, University of Adelaide, SA 5005, Australia

⁴Institute of Space and Astronautical Science, Sagami-hara, Kanagawa 229-8510, Japan

⁵Institute for Cosmic Ray Research, University of Tokyo, Kashiwa, Chiba 277-8582, Japan

⁶Department of Physics, Yamagata University, Yamagata, Yamagata 990-8560, Japan

⁷Department of Physics, Tokyo Institute of Technology, Meguro-ku, Tokyo 152-8551, Japan

⁸Faculty of Management Information, Yamanashi Gakuin University, Kofu, Yamanashi 400-8575, Japan

⁹Department of Physics, Konan University, Kobe, Hyogo 658-8501, Japan

¹⁰Faculty of Science, Ibaraki University, Mito, Ibaraki 310-8512, Japan

¹¹Faculty of Engineering, Shinshu University, Nagano, Nagano 380-8553, Japan

¹²STE Laboratory, Nagoya University, Nagoya, Aichi 464-8602, Japan

¹³National Astronomical Observatory of Japan, Mitaka, Tokyo 181-8588, Japan

¹⁴Ibaraki Prefectural University of Health Sciences, Ami, Ibaraki 300-0394, Japan

¹⁵Department of Physics, Tokai University, Hiratsuka, Kanagawa 259-1292, Japan

¹⁶Department of Physics, Osaka-city University, Osaka, Osaka 558-8585, Japan

Abstract. We report the development of the data acquisition system of the CANGAROO-III imaging Cherenkov telescope. Multi-pixel cameras consisting of 552 and 427 PMTs are placed at the prime focus of the first and second telescopes respectively. The charge and hit timings of each PMT are measured with ADCs and TDCs respectively via a fast VME-bus which is selected to reduce the data acquisition time. The VME-bus data are read by computers running a linux OS. Furthermore a module to select hit pattern in hardware whether triggered PMTs are adjacent or not will be installed to the second telescope. In CANGAROO-III observations, a global trigger is generated by the coincidence of the local triggers of the four telescopes, and the event data is collected via fast-ethernet, and analyzed with the central event-builder. The data acquisition system of each telescope is designed to accept triggers up to 100 Hz.

1 Introduction

The CANGAROO-III project to construct an array of four 10 m imaging atmospheric Cherenkov telescopes is underway in Woomera, South Australia (Mori et al., 2001a,b; Tan-

imori, 2001). Observations with the first telescope started in March 2000, and results are presented in these proceedings (Enomoto et al., 2001; Hara et al., 2001; Kushida et al., 2001; Nishijima et al., 2001; Okumura et al., 2001). The second telescope will be constructed at the end of 2001, and the overall status of CANGAROO-III is presented in Mori et al. (2001b). In this paper we report the data acquisition system (DAQ) of CANGAROO-III in detail. At first we introduce the DAQ of the first telescope, and then the improved DAQ of the second telescope.

2 First telescope

2.1 Electronics

The electronics of the first telescope before the expansion of mirror area is described in Mori et al. (1999, 2000); Kubo et al. (2000). The improvement of the DAQ after the expansion is briefly presented in Mori et al. (2001a,b). Figure 1 shows the overview of the DAQ of the first telescope. The multi-pixel camera consisting of 552 PMTs (Hamamatsu 4124UV, 1/2" in diameter) shown in Fig.2 (Mori et al., 2001b) is placed at the prime focus, covering a field of view $2.7^\circ \times 2.7^\circ$. Common high voltages of about -700 V are supplied to blocks of 16 PMTs from the module (LeCroy 1461N). The anode

PCI-VME bridge while the TDCs and CAMAC-scaler are read via a ISA-CAMAC bridge. This is done when a DAQ trigger, shown in Fig. 3, is generated and the CPU of PC2 is interrupted by a CAMAC interrupt register. PC2 runs linux operating system version 2.2, and a portable DAQ system “UNIDAQ” (Nomachi et al., 1994) is installed for collecting and storing all data on a hard-disk. Although the DAQ trigger rate is below 30 Hz in most observations, the DAQ system can accept 80 Hz triggers with a dead time 20%. The UNIDAQ system is also used on the VME-bus CPU board in the left side in Fig. 1. The total size of an event is 1.5 kbytes, and at most 45 kbytes/sec.

For realtime quick analysis, a part of observation data is transmitted via the 100-Base network to a PC (PC3 in Fig. 1) on which linux is running, and both ADC and TDC distributions of all PMTs are displayed on event monitor windows. PC3 is connected to the high voltage controller of PMTs via RS232C lines, and both applied voltage and measured current are displayed on the window. PC3 also calculates the positions of stars from a realtime position of the telescope and displays them on the map of PMTs in order to compare their positions with PMTs with high DSM scalars. If the positions are different, observers are alerted to check for telescope drive problems or discharge of PMTs. PC3 also plays a part in serving the system clock to all other CPUs via network as a NTP server.

3 Second telescope

The DAQ system of the second telescope to be constructed is an improved one based on the experiences of the first telescope. An overview of the DAQ system of the second telescope is shown in Fig.4. The biggest difference between the DAQ of first telescope and that of the second telescope is the kinds of data-bus. The read-transfer speeds of both CAMAC and TKO data-bus are at most 1 M bytes/sec, while that of VME (VME32 type) is 8 M bytes/sec. Thus only VME-bus is adopted for the second telescope to speed up the readout time.

3.1 Electronics

The multi-pixel camera consisting of 427 PMTs (Hamamatsu R3497UV, 3/4” in diameter) shown in Fig.5 (Mori et al., 2001b) is placed at the prime focus, covering a field of view about 4 degrees. High voltages of about +1kV are supplied to PMTs from modules (CAEN SY527, A932) which control the voltage in each channel via a CAENET VME-bus controller (CAEN V288). Although the high voltages of the first telescope are negative, positive voltages are selected for the second telescope in order to avoid discharge between the PMT photocathode and the lightguide. The anode signal from each PMT is amplified with an operational amplifier (Maxim MAX4107) attached behind the PMT, and then transmitted through differential twisted cables 28m in length to electronics circuits, which are placed in the cabin attached

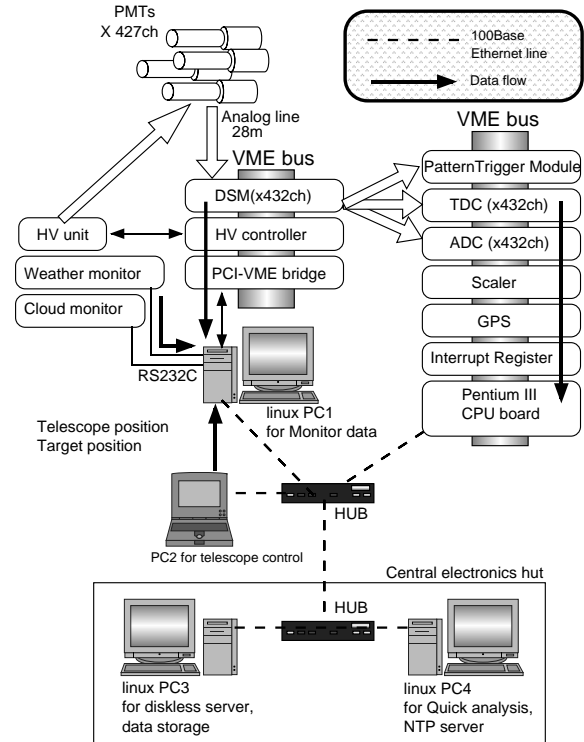

Fig. 4. Overview of data acquisition system of the second telescope.

to the telescope shown in Fig.3 (Mori et al., 2001b) to shorten the cables. The signal from each PMT is fed to DSMs shown in Fig. 2. The DSM of the first telescope adopted a TKO-bus, but a VME-bus (CERN V430 type) is used for the second telescope. In the DSMs the signal is inverted according to polarity of the VME9U-bus (CERN V430 type) 32ch 15bit charge ADC (HOSHIN 2678). The ADCs of the second telescope are improved from the ADCs of the first telescope; simultaneous readout of 2 channels speeds up the VME-bus readout, and the number of ADC chips (BB ADS7805 or ADS7815) is increased from 2 to 32 to convert signals in parallel. The updating discriminator in the DSM is fed to VME-bus 128ch TDC (CAEN V673) which has 1 nsec resolution, and both the leading and trailing edges are recorded. The non-updating discriminator is fed to a pattern trigger module, but can be switched off via VME-bus for rejecting triggers from noisy PMTs. Outputs of LSUM, ASUM and scalars are as same as those of the first telescope.

A pattern trigger module will be installed on the second telescope for the first time. In the first telescope a DAQ trigger is generated from the summed LSUM signal as shown in Fig. 3. It only requires the coincidence of any $N(4 \text{ or } 5)$ PMT triggers and ignores the pixel pattern. If the threshold in the DSM is lowered, the trigger rate due to the fluctuating night-sky background increases. However it is possible to reduce the night-sky background because the hit pattern due to the night-sky background is random, while that of showers are concentrated. Thus the pattern trigger module accepts hit signals of all 427 PMTs and recognizes the 2-dimensional pixel pattern, then generates a trigger if there is pattern of

$N(\geq 3)$ adjacent pixels. PLDs (Altera EPF10k130) are used for the pattern selection, and take less than 100ns from input to output according to the design simulator. The power of this module is supplied via the VME-bus.

Both weather and cloud monitors are connected to a PC (PC1 in Fig. 4) with RS232C lines, and read once a minute. In first telescope the operating system of Solaris is adopted, but in second one a linux is to be used because the context switching time of linux is $2\mu\text{s}$ while that of Solaris is at most $20\mu\text{s}$. The PC1 also collects the scalers in the DSMs via a PCI-VME bridge every 10 seconds, and the realtime position of the telescope via a 100-Base network from a PC(PC2 in Fig. 4) which controls the telescope. Further the PC1 controls the VME-bus high-voltage controller described above.

3.2 Local and global trigger

The four telescopes of CANGAROO-III will be placed at the corners of a diamond with sides of about 100 m. In stereoscopic observations with more than two telescopes, a global DAQ trigger is generated as shown in Fig. 5. In each telescope a local DAQ trigger from the pattern trigger module opens the gate of the ADCs of each telescope, and the trigger is converted to an optical signal and transmitted to the central electronics hut through optical fibers about 100 m in length. The local trigger of each telescope is delayed with a VME-bus controlled delay generator, whose delay is set by realtime calculation of the difference of path lengths of Cherenkov light, using the pointing directions of the four telescopes. The four delayed triggers are fed to a coincidence unit, which generates a global trigger which stops a TDC to measure the time difference of the local triggers of the four telescopes.

The global trigger is distributed to the four telescopes, and it interrupts the VME-CPU's (Pentium III 700MHz) via a VME interrupt register, then starts to collect data from the ADCs, TDCs, scalers, and GPS via the VME-bus. The system is designed to accept triggers up to 100 Hz. However if a global trigger is not generated in $2\mu\text{s}$ after a local trigger is generated, these readout modules are to be reset in each telescope. In the first telescope, non-realtime linux is used for event data collection, but a realtime linux will be adopted in the second telescope to reduce the deadtime. The VME-CPU's transmit all collected data to a PC (PC3 in Fig. 4) in the central electronics hut, and the data is stored on hard-disks connected with PC3. PC3 is also a diskless server of VME-bus CPU's of the four telescopes. Another PC (PC4 in Fig. 4) in the central electronics hut reconstructs the event from the data for quick analysis, and plays a role as a NTP server.

4 Summary

The DAQ system for an array of CANGAROO-III telescope has been developed in order to explore the southern sky in the gamma-ray band above 100 GeV. The first telescope of

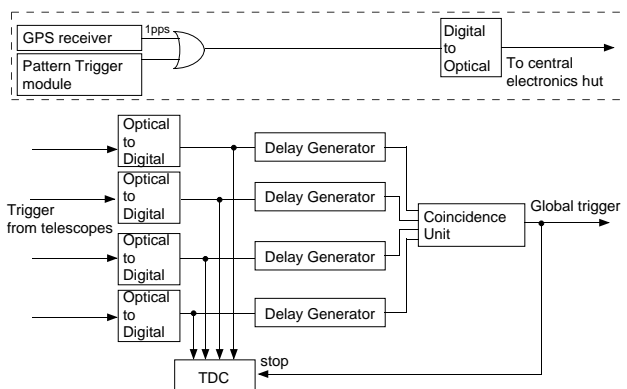

Fig. 5. Global trigger of four telescopes. The area enclosed with dash lines shows a local trigger of each telescope.

CANGAROO-III has been in operation from 2000, and the DAQ system of the second telescope is now being built to improve performance, based on that of the first one. The system of the first telescope consists of three data-buses, e.g. TKO, CAMAC, and VME, and two operating systems, linux and solaris, while that of the second telescope consists of only VME-bus and linux-OS to speed up the readout time. A module to select hit pattern in hardware whether triggered PMTs are adjacent or not will be installed to the second telescope instead of the present selection of N hits of any PMTs in order to reduce the night-sky background. In stereoscopic observations, a global trigger is generated from coincidence of four telescope with variable delay generators using telescope positions. All observation data of four telescopes are transmitted to the workstation in the central electronics hut and stored, and the events are reconstructed.

Acknowledgements. This work was supported by the Center of Excellence, and a Grant-in-Aid for Scientific Research by the Japan Ministry of Education, Science, Sports and Culture. Also it was supported by Australian Research Council.

References

- Enomoto, R. et al., in these Proceedings, 2001.
- Hara, S. et al., in these Proceedings, 2001.
- Kubo, H. et al., in Proc. *GeV-TeV Gamma-ray Astrophysics Workshop* (AIP Conf. Proc. 515), p.313, 2000.
- Kushida, J. et al., in these Proceedings, 2001.
- Mori, M. et al., in Proc. 26th ICRC, Vol.5, p.287, 1999.
- Mori, M. et al., in Proc. *GeV-TeV Gamma-ray Astrophysics Workshop* (AIP Conf. Proc. 515), p.485, 2000.
- Mori, M. et al., to appear in Proc. *High Energy Gamma-ray Astronomy* (Heidelberg, Germany; AIP Conf. Proc. 558), p.578, 2001a.
- Mori, M. et al., in these Proceedings, 2001b.
- Nishijima, K. et al., in these Proceedings, 2001.
- Nomachi, M. et al., in Proc. *Int. Conf. on Computing in High Energy Physics '94*, LBL-35822, p.114, 1994.
- Okumura, K. et al., in these Proceedings, 2001.
- Tanimori, T. et al., in Proc. 26th ICRC, Vol.5, p.203, 1999.
- Tanimori, T., to appear in Proc. *High Energy Phenomena in the Universe*, (January 20–27, 2001, Les Arcs, France), 2001.